

FREE COOLER



Free cooling unit for telecommunication shelters

UNIT DESCRIPTION

Designed for the cooling of highly technological environments (telecommunication shelters and cabinets), FKO/FKI FREE COOLER units feature an advanced free cooling system that utilises the outdoor air to lower the indoor environment temperature. Outdoor air absorbed from the fan is filtered and then released to the indoor space.

The unit is available in indoor (FKI) or outdoor versions (FKO), in both cases provided with a waterproof jacket in order to avoid even a drop of water from entering the environment. Directly managed by the PLC controller, the units can be coupled to a TELECOM air conditioner s range. This ensures getting the best advantage from the free cooling operation, whenever possible.

For the stand-alone operation an electrical board kit able to manage the unit and two further pre-existing air conditioners are also available. In pre-existing plants, this solution offers the opportunity to add the free cooling function at a later date.



FEATURES

- ✓ Structure and panelling in electrogalvanised powder coated steel sheets for maximum resistance to rust.
- ✓ Total reliability and functionality of the compressor and all other components guaranteed by leading companies in the telecom sector.
- ✓ 48 VDC EC radial fan with continuous speed modulation.
- ✓ Class G3 air filters.

MAIN OPTIONS

- ✓ Electrical panel for the unit's stand-alone management.
- ✓ Clogged filter sensor.
- ✓ Air prefilter in metal frame.

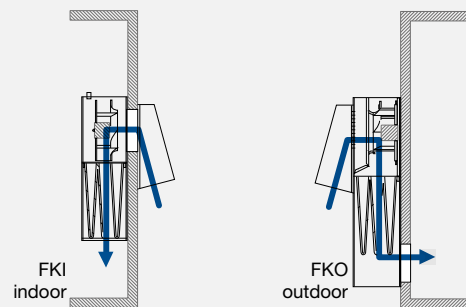

INDOOR / OUTDOOR Technical Data

| FREE COOLER | | 0021 | 0041 | 0051 |
|--------------------------------|-------------------|-------|-------|-------|
| VDC power supply | V | 48 | 48 | 48 |
| Max absorbed power | W | 220 | 230 | 460 |
| Max air flow | m ³ /h | 2300 | 2450 | 3040 |
| Cooling capacity (1) | kW | 7,67 | 8,17 | 10,13 |
| EER | kW/kW | 34,85 | 35,51 | 22,03 |
| Max frontal sound pressure (2) | dB(A) | 62 | 65 | 66 |

(1) Ref. Conditions: 27°C indoor temperature -17°C outdoor temperature
 (2) Measured at a height of 1 m and 1 m from the front of the unit in free field
 The dimensions between () include rain proof cover, when foreseen

DIMENSIONS (mm)

FREE COOLER

| | a | b | c |
|----------|-----|-----------|------|
| FKI 0021 | 646 | 296 | 955 |
| FKI 0041 | 646 | 296 | 955 |
| FKI 0051 | 646 | 296 | 955 |
| FKO 0021 | 646 | 296 (542) | 1227 |
| FKO 0041 | 646 | 296 (542) | 1227 |
| FKO 0051 | 646 | 296 (542) | 1227 |

